

WARNING



***Buyer/User Assumes All
Responsibility For Safety And
Proper Use Not In Accordance With
The Directions And Safety Labels.***

P.O. Box 1210, Camarillo, CA 93011-1210 | www.ViaAquaOceanpure.com



WARNING!

Buyer/user assumes all responsibility for safety and proper use not in accordance with the directions and safety labels.



MODULAR ViaAqua®
CANISTER FILTER

UTC-3200, UTC-3200UV, UTC-3400 and UTC-3400UV



Features

- **DESIGNED TO SUPPORT AQUATIC LIFE AND ENGINEERED FOR THE HOBBYIST.**
- **Quiet, Energy Efficient.**
- **Easy to set-up, install and maintain.**
- **Modular design for variety filter medias.**
- **UV model equipped with UV Sterilizer.**
- **Standard UTC model equipped with priming plunger**
- **Distinctively Superior Filtering System.**
- **High Performance External Filter.**
- **Heavy Duty Latches.**
- **Water Tight Seal.**
- **Built-in Handle, for Easy Carrying During Maintenance.**
- **Filtering Baskets, with Separate Grids for Various Filtering Media Allowing Efficient Four Step Filtration:**
 - 1. Mechanical**
 - 2. Biological**
 - 3. Chemical**
 - 4. UV Sterilizer** (for Model with UV Sterilizer only)
- **Durable Ceramic Shaft for Freshwater and Marine aquariums.**
- **Oil Free Motor.**
- **Anti-Slip Rubber Feet.**

Specifications

Technical Data				
Model	GPH/LPH	Power Consumption	Filter Volume	Aquarium Size
UTC-600	194/740	13 Watts	1.26 Gal.	10 -40 Gal.
UTC-800			1.58 Gal.	15 -60 Gal.
UTC-1000	355/1350	28 Watts	2.5 Gal.	20 -70 Gal.
UTC-1200			3.16 Gal.	20 -90 Gal.
UTC-3200	581/2200	55 Watts	4.74 Gal.	80-210 Gal.
UTC-3200UV		63Watts		
UTC-3400		55 Watts	5.79 Gal.	80-240 Gal.
UTC-3400UV		63Watts		

Dimensions				
Model	Length (in.)	Width (in.)	Height (in.)	UPC# 0069037
UTC-600	8.8	8.8	13.6	2944 4
UTC-800	8.8	8.8	15.6	2945 1
UTC-1000	10.4	10.4	16	2946 8
UTC-1200	10.4	10.4	18.8	2947 5
UTC-3200	13.2	13.2	18.8	2948 2
UTC-3200UV	13.2	13.2	18.8	2949 9
UTC-3400	13.2	13.2	21.6	2950 5
UTC-3400UV	13.2	13.2	21.6	2951 2

Parts List of Standard UTC Model

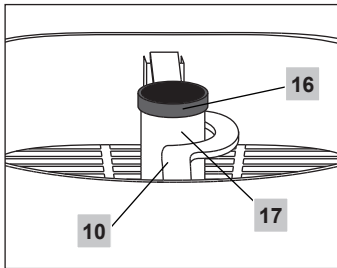
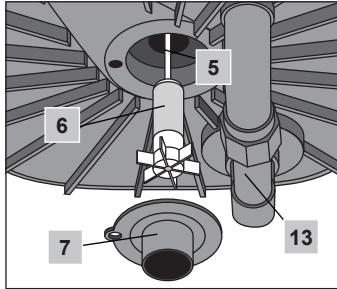

1. Valve lever
2. Valve and tap connector
3. Pump lid
4. Latches
5. Ceramic shaft
6. Impeller
7. Impeller cover
8. Filter sponge coarse
9. Filter wool pad fine
10. Retractable handle
11. Media container
12. Filter container
13. Priming plunger
14. Priming tube
15. Pump lid intake tube
16. Rubber seal
17. Discharge pipe
18. Intake elbow
19. UV intake slot
20. UV PL light bulb 5 watts
21. Quartz sleeve and reaction chamber

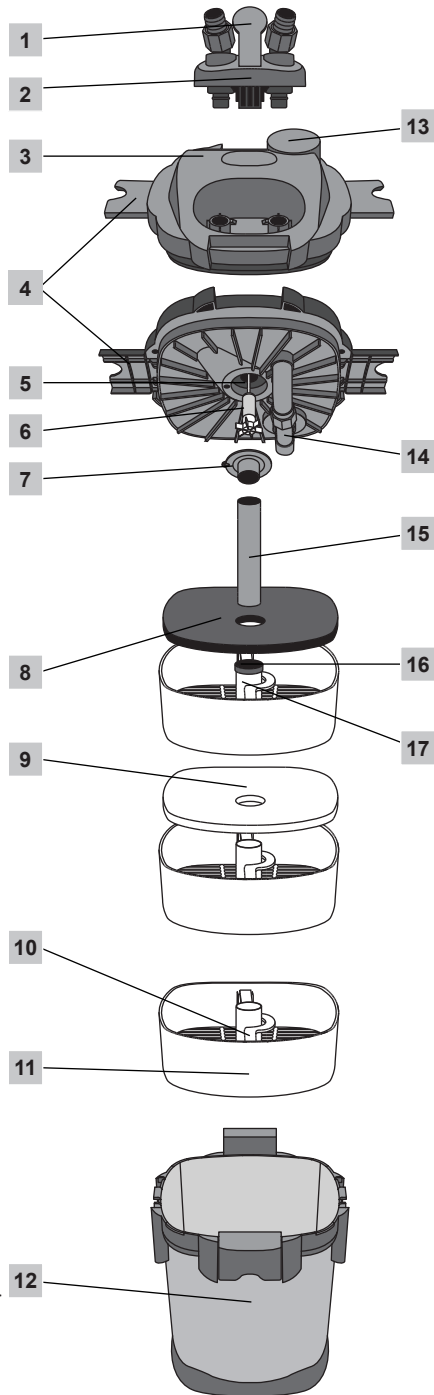

②

Part List of UV Model

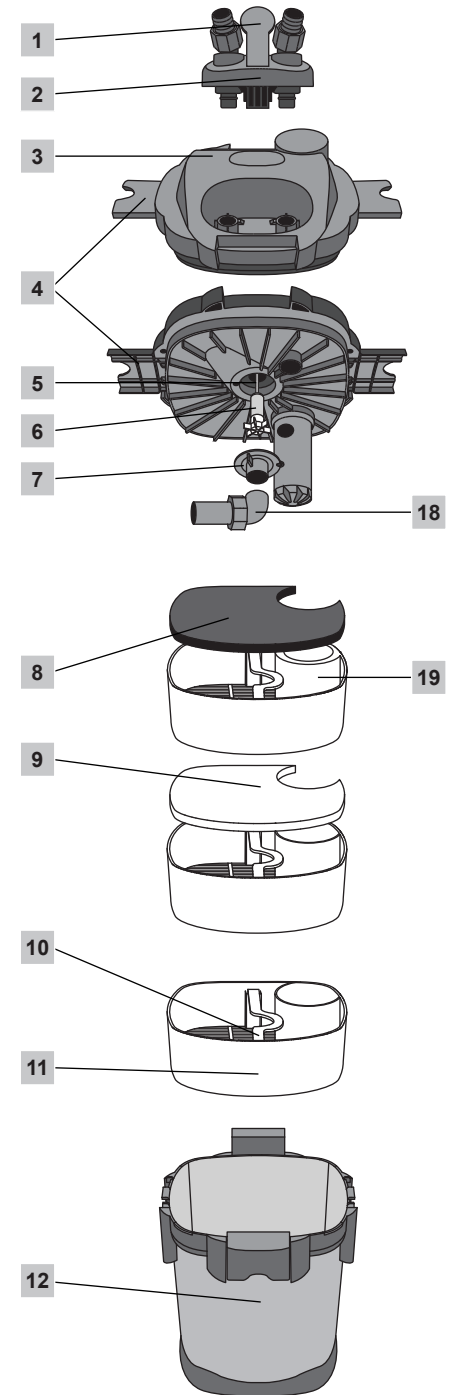
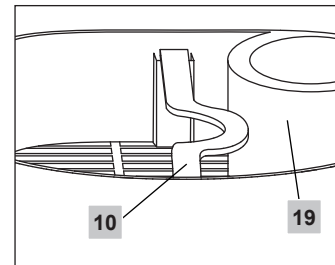
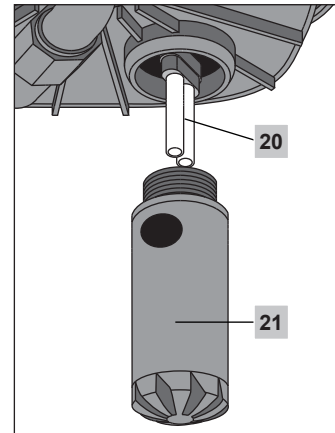
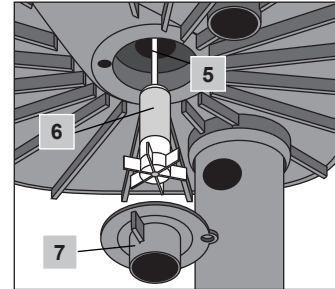

③

Parts List

- 22. Tubing
- 23. Pump lid O-ring
- 24. Suction cups
- 25. U-shape intake pipe
- 26. Priming cap
- 27. Surface skimmer
- 28. Extensions
- 29. Couplers
- 30. Intake strainer
- 31. U-shape return pipe
- 32. Output elbow
- 33. Spray bars
- 34. Spray bar cap

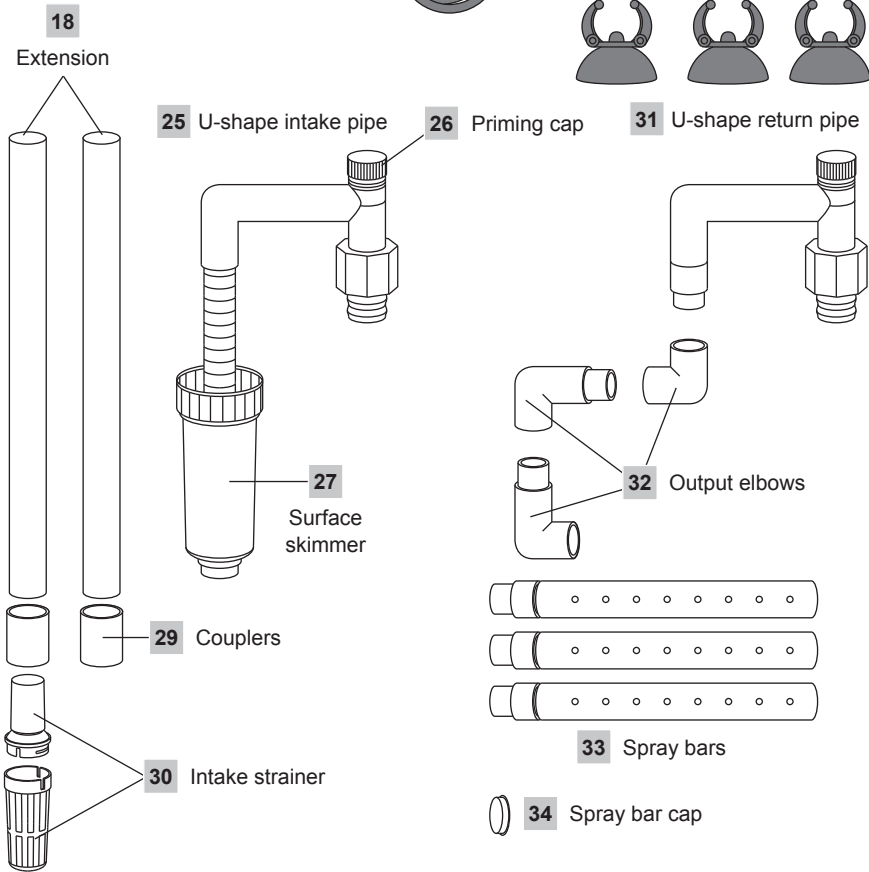

Warning and Safeguards

Do not deviate from the following Warning and Safeguards.

Before installation of a ViaAqua® Modular Canister Filter, read and follow these important Warning and Safeguards.

This product may contain chemicals known to the state of California to cause cancer and or birth defects or other reproductive harm. Wash your hand after handling this product.

It is your sole responsibilities to verify that the plug and the receptacle are clean and free of moisture and salt build up at all times. The receptacle must be free of water, salt, calcium, magnesium and dust. Failure to do so can cause fire, damage to property, permanent damage to the product and personal injury not limited to loss of life.

Do not plug into extension cord/power strip.

A drip loop must be used when plugging all electrical aquarium devices. A drip loop is that part of the cord hanging below the receptacle.

The national code requires that a GFCI (Ground fault circuit interrupter) be used in the branch circuit supplying all power to water pumps and electrical aquarium equipment. If you do not have a GFCI, have an electrician install one prior to operating any aquarium component.

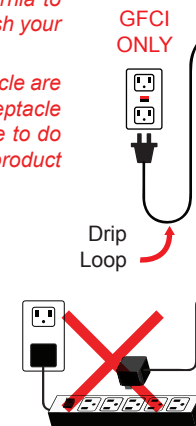

- Do not operate ViaAqua® Modular Canister Filter without water. Doing so can cause permanent damage to the canister filter.
- Carefully check the canister filter after installation to ensure that the canister filter and the tubing connecting the canister to the aquarium are not wet.
- Prior to maintenance on any electrical aquarium appliance or maintenance to the aquarium, you must disconnect all electrical aquarium devices.
- Use this product for its intended use only.
- Verify that tubing and the canister filter are not in contact with moving parts or hot parts such as heaters.
- Routine maintenance is required to ensure the maximum performance and the longevity of the ViaAqua® Modular Canister Filter. See maintenance guidelines.
- The use of a surge suppressor is strongly recommended.
- Never yank or pull the cord from the electrical outlet.
- Do not operate if the plug or wire is damaged.

Warning! For all Models with a UV sterilizer

- Do not look at UV bulb when lit. Exposure to ultra-violet light can damage eyes and skin.
- Do not open the filter when the pump and filter are operating.

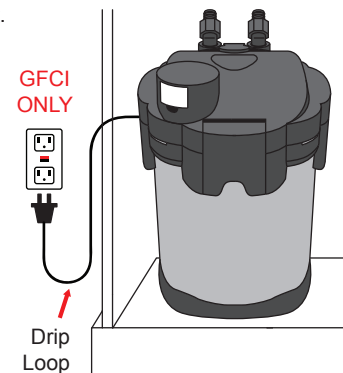

Installation

1. Remove the pump lid

- Flip out all 4 latches. Two on the canister and two on the pump lid.
- Lift the pump lid off of the canister.

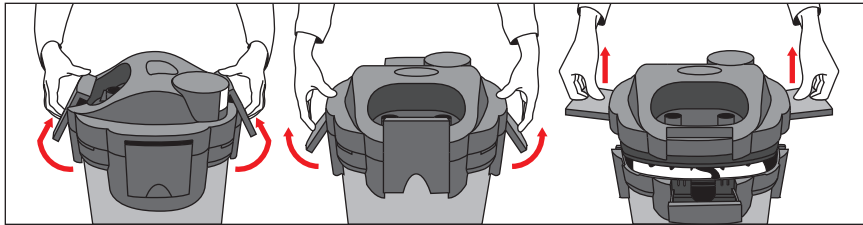

2. Install pump lid O-ring

Note: The O-ring has been pretreated with silicone lubricant to ensure a proper seal.

- Remove O-ring from the sealed bag. Place O-ring in the groove in the pump lid.
- Verify that the O-ring is not soiled.

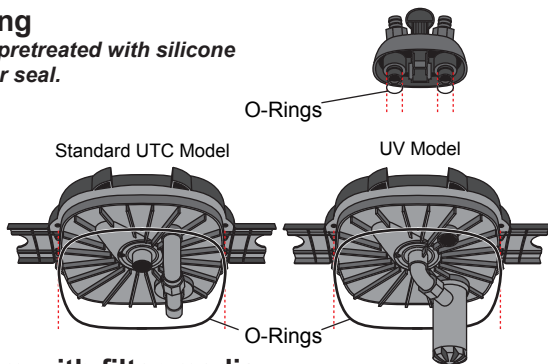

3. Take out the media containers to fill them with filter media

Note: The media containers will have to be replaced in the order they were removed.

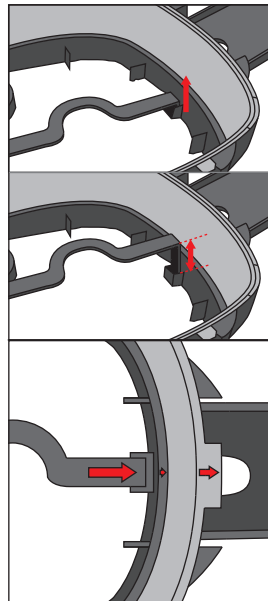
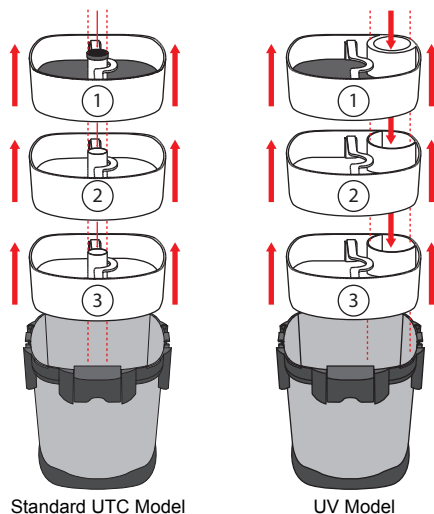

⑥

- Take out the media containers one at a time.
- The retractable handles of the media containers can be pulled out in an upward direction for removal.
- Recommended media below for three stage filters:
Top: Filter pads (filter sponge coarse and filter wool pad fine).
Middle: Carbon or resin filtering media. Media needs to be placed in a media bag.
Bottom: Biological media.

4. Replace filled media containers:

Note: Media containers must be placed back in the order they were removed

- Align the media containers guide arrow with the arrow on the brim of the canister.
- Place the media containers back into the canister. Start with media container #3.
- Position container #3 firmly within the support frames on the bottom of the canister.
- Stack the remaining containers.

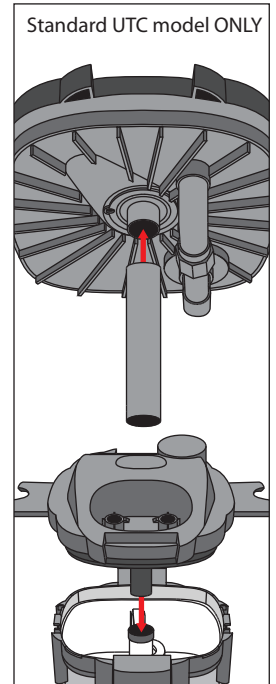

5. Replace the pump lid:

- Check to make sure the pump lid O-ring is not soiled and that it is in the proper groove.
- Use silicone lubricant is recommended to ensure a good seal. Add silicone lubricant directly to the O-ring.
- Attach the pump lid intake tube to the impeller cover.
- Place media container gasket onto media container #1 discharge pipe.
- Insert the pump lid intake tube into the discharge pipe until the pump lid comes in contact with the canister.
- Press directly down on the top of the pump lid. The pump lid must be flush with the canister filter prior to securing. Latch and secure.

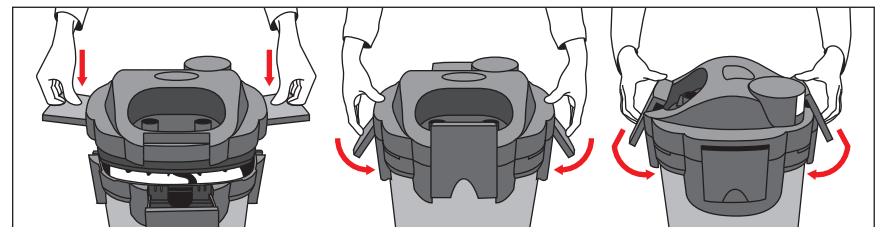

6. Connect the valve and tubing tap connectors to pump lid:

- Position the valve hold so that it is in a vertical position. Hold the valve and tubing tap connector so that you can read the "out" and "in" and press directly into the pump lid.
- Press down valve lever towards pump lid to secure.

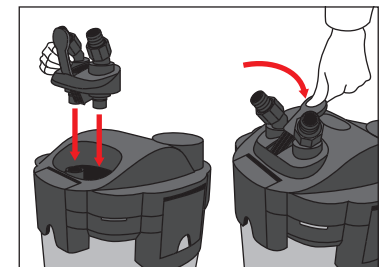

⑦

7. Position canister filter

Place the canister filter into the cabinet or floor beneath the aquarium. Surface needs to be level.

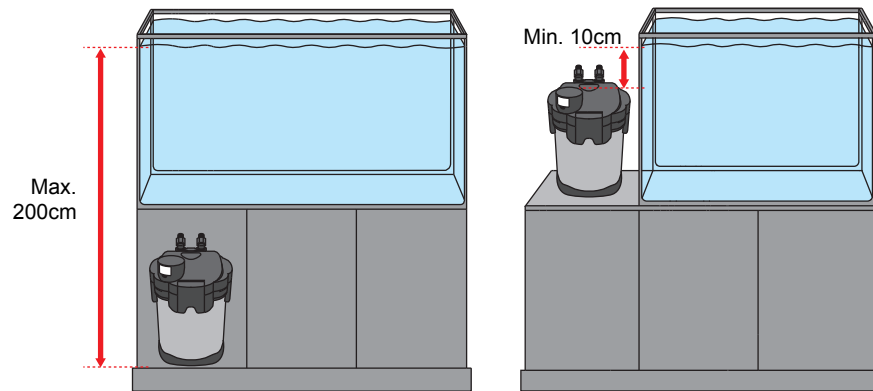

8. Intake and output tube set-up

Intake tube set up:

Note: If you use the surface skimmer the water level must stay the same once the surface skimmer is set. Failure to do so will cause air bubbles to enter the canister and the unit may loose prime.

- Open the bag of Intake tube parts.
- Connect the surface skimmer to the U-shape intake pipe. Surface skimmer water level should be $\frac{1}{4}$ " to $\frac{3}{8}$ " from the bottom of the slots.
- Connect the extension to the bottom of the surface skimmer.
- Connect the intake strainer to the extension.
- Connect flexible tubing and secure with the lock nut.
- Secure the intake tube with suction cups so that the intake tube is vertical.
- Verify that the intake strainer is a min. of 2" from the substrate.

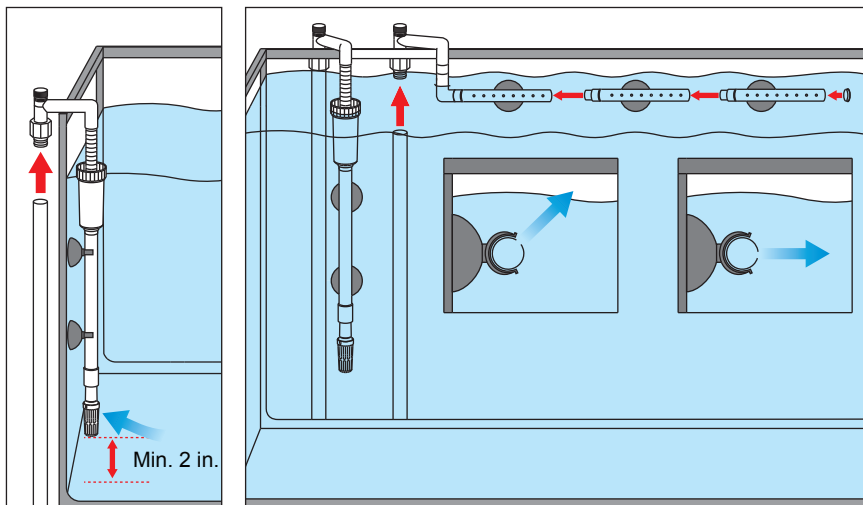

8

Output tube set up:

- Open bag of output parts.
- Connect U-shape return pipe to output elbow.
- Connect output elbow so that the spray bar is just below the water level.
- Connect flexible tubing and secure with the lock nut.
- Secure spray bar with suction cups.

9. Determine the length of tubing

Note: It is very important not to cut the tubing too short. If the tubing is cut to short and creates tension on the valves the unit will leak. Additionally, leaving the tubing too long may prevent the unit from priming. There cannot be any kinks in the tubing.

Now determine the length of tubing required to attach the Inlet and Output pipes to the aquarium. Add an extra 6" of tubing to the length of the tube to avoid cutting tubing to short. The tubing needs to be installed so that there are not any kinks in the lines.

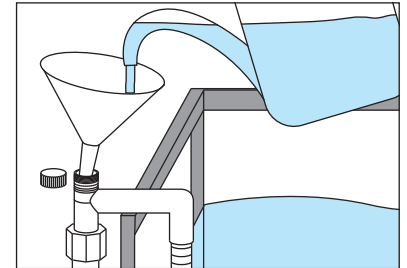

10. Starting your filter:

Note: There must be water in the aquarium to start.

- Fill canister with water. $\frac{1}{3}$ full.
- Place the valve lever in the "off" position.
- Now unscrew the priming cap on the intake prime/ U tube.
- Using a small funnel fill the intake tube until full.
- Turn valve lever to the "on" position. This will start a siphon and air bubbles and/or air will exit the spray bar.
- Once the canister is filled and the output tube has water, Plug unit into a GFCI outlet.
- If it does not start, press the priming plunger several times and restart unit. Units only without a UV.
- When starting the filter after routine maintenance, canister can be placed without water. Replace valve and tubing tap connector. Once valve is sealed in place a siphon will start filling the canister. Once all air is forced out of the unit, canister, and tubes are filled, restart unit.

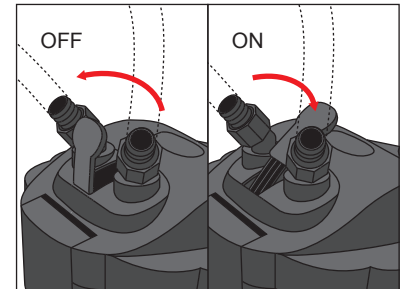

11. Once the filter is running double check all the fittings and seals to verify there are not any leaks.

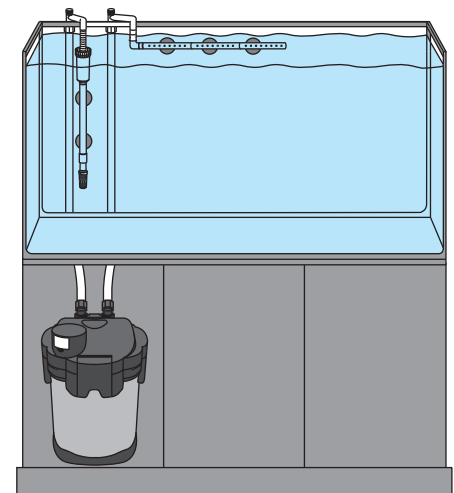

9

Maintenance

To ensure optimum filtering and to maintain full water flow regular maintenance is required. It is recommended to clean or change filtering media at least every 4 weeks. Decreased water flow is a sign of clogged filter media.

1. Unplug the unit from the GFCI outlet. Prior to maintenance on any electrical aquarium appliance or maintenance to the aquarium, you must disconnect all electrical aquarium devices.
2. Remove valve/tap connectors from pump lid.
3. If cover is removed without removing valve/tap connectors water will siphon onto the floor..
4. Remove the canister and place in an area suitable for maintenance.
5. Flip out each of the four lid housing clips and release the pump motor housing. The motor housing cannot be lifted off the canister.
6. Remove the filter strainer and remove the media containers one at a time using the handle. Note the media containers need to be replaced in the same order removed.
7. Replace filter pads and medians.
8. Clean the canister and impeller/impeller housing.
 - A. Remove the impeller cover.
 - B. Remove the impeller and shaft, clean with water. With a small brush clean the inside of the impeller well.
 - C. Do not clean with soap.
 - D. Reassemble.
9. Apply a small amount of silicone sealant to the gasket/o-ring to insure a good seal.
10. Install according to the directions for installation.

Note: When starting the filter after routine maintenance, canister can be placed without water. Replace valve and tubing tap connector. Once valve is sealed in place a siphon will start filling the canister. Once all air is forced out of the unit, canister, and tubes are filled, restart unit.

Trouble Shooting

Problem: Canister will not prime or pump water

Solutions:

1. There is no water in the aquarium.
2. The impeller needs to be cleaned. Verify that the impeller spins freely on the shaft.
3. Air is in the impeller well. Unplug and tilt the unit until air evacuates and restart.
4. The intake and the output are switched on the motor housing, connect the intake to the "IN" and the output to the "OUT" on the motor housing.
5. There is not any water in the intake tube. Fill intake tube by removing the priming cap.
6. The spray bar endcap is not at the end of the spray bar and is blocking the water flow.

Problem: Excess noise

Solutions:

1. It is not uncommon to have a rattling noise during set-up and while the unit is trying to remove the air in the canister.
2. The intake of the canister filter is sucking in air. Relocate all air stones and air powered ornaments to an area of the aquarium away from the intake of the canister filter.
3. Impeller and the impeller well needs to be cleaned.
4. Canister needs to be cleaned.
5. Shaft and/or impeller is damaged and needs to be replaced.

Problem: Slow water flow

Solutions:

1. Medians are to tightly packed in the median containers.
2. The impeller and impeller well needs to be cleaned.
3. Tubing needs to be cleaned.
4. Canister needs to be cleaned and medians changed.
5. The intake strainer is clogged.

Problem: Leaking water

Solutions:

1. Tubing is not properly installed. Verify that the collar on the valve and tubing tap connectors are over the tubing. A clean-cut tube is essential for a good seal.
2. A small amount of silicone lubricant needs to be added to the gasket/O-ring.
3. The extra replacement O-rings were placed in the incorrect spot. Remove replacement O-ring and reinstall.

TECHNICAL SERVICE DEPARTMENT

Monday to Friday 9 am - 5 pm PST

(805) 383-3566 ext. 102

e-mail: info@commodityaxis.com

Replacement Parts

Part Number	Description
2	Valve and tap connectors
5-6	3200 Impeller and ceramic shaft
5-6	3400 Impeller and ceramic shaft
10	Filter sponge coarse. 2 pk.
11	Filter wool pad fine. 2pk.
15	Rubber seal
19	Replacement UV bulb 5 watts
20	Quartz sleeve and reaction chamber
21	Tubing set 2 x 78"
22	Pump lid O-ring
23	Suction cups. 6 pk.
24	U-shape intake pipe
24 & 26	U-shape intake pipe with surface skimmer
30	U-shape return pipe
32	Spray bar kit

Limited Warranty

Commodity Axis, Inc.® warrants that the ViaAqua® Modular Canister Filter is free from defects for a period of one year from the initial date of purchase shown on the original cash register receipt. Commodity Axis, Inc.® disclaims all other warranties, express or implied, including but not limited to any implied warranties of merchantability and/or fitness for a particular purpose. Although this limited warranty gives you specific rights, you may have other rights which vary from state to state. This warranty is void if the failure is due to misuse, tampering, negligence, abuse, accident and/or submersion, a failure to properly install, maintain, clean, prefilter, reassemble, and/or failure to use the ViaAqua® Pressure Pond Filter with a Ground Fault Circuit Interrupter (GFCI).

Consumer Remedies

Commodity Axis, Inc.® entire liability and your sole and exclusive remedy shall be either repair or replacement of the ViaAqua® Modular Canister Filter only if you return the defective unit directly to Commodity Axis, Inc.® with the original receipt in its original box along with twenty five dollars (\$25.00) for shipping and handling. Do not send the ViaAqua® Modular Canister Filter by insured mail. You may send your returns or replacements by UPS requiring a signature upon arrival. Any replaced unit will be warranted for the remaining time of the original warranty period. In no event shall any shipping charges be reimbursed. In no event will Commodity Axis, Inc.® be liable for any consequential or incidental damages, including but not limited to, lost sea life, personal injury, property damage, equipment damage, lost profits, lost wages, lost savings, lost income, etc., arising out of the use of the ViaAqua® Modular Canister Filter. Some states do not allow for the limitation or exclusion of liability for incidental or consequential damages, so the above exclusion may not apply to you.

Returns

Please contact our service center at (888) 838-3882 or fax (888) 989-0878 to arrange repair and/or replacement. Please allow 4-6 weeks for all returns. Commodity Axis, Inc.® cannot ship nor respond to a P.O. Box address.

Warranty Card

Please mail warranty card and PROOF OF PURCHASE within 15 days of purchase to:
Commodity Axis, Inc., P.O. Box 1210, Camarillo, CA 93011-1210.

Model #: _____ Customer's Name: _____

Date of Purchase: _____ Address: _____

Dealer Name: _____ Phone #: _____





P.O. Box 1210,
Camarillo, CA 93011-1210
www.CommodityAxis.com
www.ViaAquaOceanpure.com

Commodity Axis, Inc.[®] is also a manufacture of
ViaAqua[®] Acro-Cal[™] Reactor, ViaAqua[®] Poly Reactor[™],
ViaAqua[®] Oceanpure[™] Salt, ViaAqua[®] Glass Heater, ViaAqua[®] Titanium Heater,
ViaAqua[®] MillionAir[™] Air Pump, ViaAqua[®] Water Pumps, ViaAqua[®] Glass Aquariums
and Helios[®] Lighting Systems.

© 2009 Commodity Axis, Inc.[®]
Specifications are subject to change without notice